

SVM PA-35 SVM PA-55 SVM PA-110



Common Specifications for All Printers

Software: SAYASIS Template Design (Date and Time, Custom Formatted Date and Time, Text, Text Block, Merge Fields, Database Support, Counter, Logo, 1D / 2D Barcodes, GS-1 Barcodes, Table Creation Support and User-Friendly Interface) Windows Driver Support, Nicelabel Software support, Code soft Software Support, Emulator Support, Printer Management with SPPL (Savema Protocol) Commands, Printer Control with Remote Control)

Barcodes: 1D Barcodes (EAN-13, EAN-8, CODE 128, CODE 39, CODABAR, ITF 2of5, ITF 14, UPC-A,UPC-E ...), 2D Barcodes (Datamatrix, QR Code, PDF417, Aztec code...), GS-1 Barcodes (GS1-128, GS1-Datamatrix, GS1-Databar Barcodes)

Resolution: 300dpi (12 dots/mm) horizontally and vertically

Operating Temperature: 1 °C - 55 °C (34°F-131°F)

Memory: Max. 1000 Template Storage Capacity, 1GB Internal Memory, Up to 32GB USB Memory Support

Specifications	SVM PA-35	SVM PA-55	SVM PA-110
Print Area	32 mm x 250 mm	53 mm x 250 mm	107 mm x 250 mm
Print Speed	25 - 420 mm/sec	25 - 420 mm/sec	25 - 420 mm/sec
Production	Typically 160 packs per minute based on label size. Faster print-out may be possible dependent on specific application details. Label size (100*100) - 110 packs/min Label size (50*30) - 160 packs/min		
Ribbon Widths & Length	35 mm -(1,4") & 600 meters (656yards)	55 mm -(2,2") & 600 meters (656yards)	110 mm (4,28") & 600 meters (656yards)
Power Supply	100-240V 50-60 Hz		
Air Supply (Bar)	No air requirement is needed.		
Input/Outputs	Print Signal/Fault Signal, Busy Signal		
Output Messages	Update Error, Ribbon Break / Not Found Error, Remaining, Label Diameter, Number of Printed Templates, Number of Prints per Minute, Missing Label		Update Error, Ribbon Break / Not Found Error, Remaining Label Diameter, Number of Printed Templates, Number of Prints per Minute, Missing Label
Connection Types	Relay(NPN, PNP) - Photocell(NPN, PNP)		
Communications	RS-232, Ethernet, USB,Wifi		
Advanced Control	7" Touch Screen Control, Template Changing while Running, Print Position Adjustment, Contrast, Print Delay, Template-Specific Adjustment, Internal Contact Signal, Multi-print Contact Signal, Template Shifting, Template Rotation, Labelling Delay, Reduction mode, Labelling Method (Encoder Adjustable Speed, fixed speed), Dispenser mode, Blow out, Automatic Label Length Detection, Automatic TPH Gap Adjustment		
Operator Interface	7" 1024x600 Pixels Resolution, Full-color display, Password protection on menu, Multi-language(20) support		
Weight (Printer)	30-35 Kg.	30-35 Kg.	30-35 Kg.
Dimensions	625mm H x 600mm W x 390mm D	625mm H x 600mm W x 390mm D	625mm H x 600mm W x 390mm D

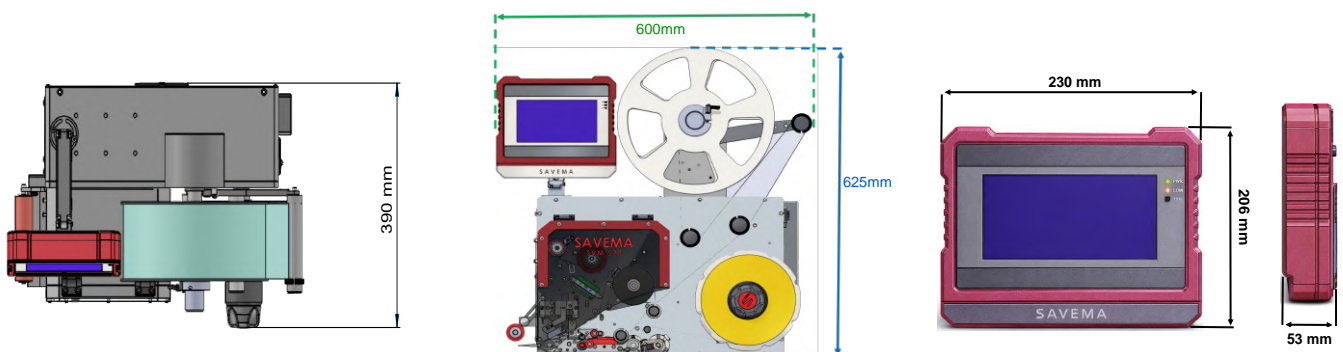

PRINT & APPLY WITH BLOW OUT MODULE

Technical Specifications	
Min. Label Width	40mm X 40mm
Max. Label Width	100mm X 100mm
Label Speed	90 Labels/Min. (Max)
Air Supply	6-8 Bar (the line requirement should be 10 bar)
Compatibility	PA-35, PA-55, PA-110



PLAY VIDEO



Application Accuracy

- +/- 2mm from 5cm distance on 100x100 labels
- +/- 4mm from 10cm distance on 100x100 labels
- +/- 2mm from 5cm distance on 40x40 labels
- +/- 4mm from 8cm distance on 40x40 labels

PRINT & APPLY WITH DIRECT APPLY

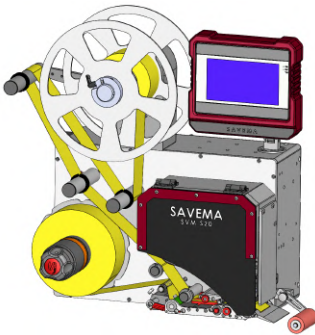

Left Hand Side

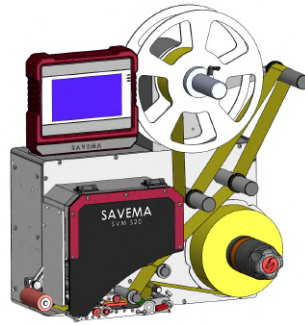

Right Hand Side



- Thermal ribbon options of 35mm, 55mm, and 110mm are available to suit your needs.
- A helpful product for labeling cardboard, plastic, and pallets.
- Printing barcodes, dates, and content at 300dpi (12 dots/mm) print quality.
- Easy integration into production line



PLAY VIDEO

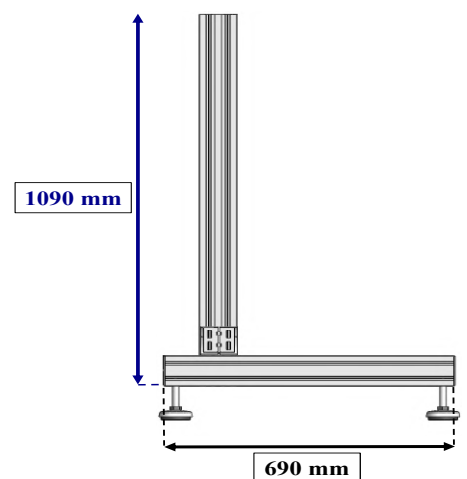
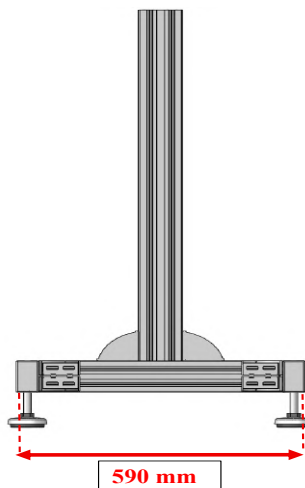

Savema

Büyükkayacıkosb mah. Kuddusi Cad.
No: 4 42280
Selçuklu / Konya / TÜRKİYE

Tel : +90 332 239 23 39
Fax: +90 332 239 23 19

www.savema.com.tr
info@savema.com.tr